



## 1.0 Installation

Carefully unpack the 1501. Note the feed table (Item 1) and the 2nd fold table (Item 34) are packed separately within the box, and will be installed later. Carefully inspect carton contents for damage. Report any shipping damage to the carrier and your Martin Yale Dealer. Place the folder on a flat, level work surface.

Connect power to the machine. Turn on the machine and let it run for a few minutes. During this process you may hear a thumping sound caused by flat areas on the rubber folding rollers. These flat areas occur during long periods of non-use and will be eliminated during this initial run. If your folder is inactive for long periods, you should repeat this process before attempting to fold paper. **NOTE: Failure to do so may cause folding problems.**

**NOTE: Never handle the feed table by the paper guides.** Install the feed table onto the 1501. To do so, lower the retarder roller (Item 4) by loosening the thumb nut (See Figure 3.) under the feed table until the retarder roller is level with the top of the feed table. Slide the left and right paper guide rollers (Item 14) on the feed roller shaft until they are next to the feed roller. Install the feed table by placing the front slots of the feed table onto the locating pins near the folding rollers (See Figure 1.), and lower onto positioning pins.

Install the 2nd fold table (Item 34). To do so, install the fold table over the two tie rods (Item 31) located just below the feed table. (See Figure 2.) The 2nd fold table can be installed in two ways; with the open (folding) end, or the closed (deflector) end toward the folding rollers, as needed for the fold being made.

## 2.0 Setup

### 2.1 Paper Guides

Adjust the feed table paper guides (Items 2 & 5) so the sheet is centered over the feed roller (Item 12) and paper slides freely down between the guides without excessive side play. To adjust, grip the guides at the top and bottom where they are held in place on the cross shaft and slide into position. **NOTE: Improper setting of the feed table paper guides may cause inconsistent folding or crooked folds.**

### 2.2 Paper Guide Rollers

The paper guide rollers (Item 14) should be positioned approximately 1/4" to 1/2" from the left and right edge of the paper. Always slide the left and right paper guide rollers on the feed roller shaft until they are next to the feed roller before installing or removing the feed table.

### 2.3 Feed Adjustment

The retarder roller (Item 4) can be set in two ways, with power off, and power on. For power-off setting, place one sheet of paper between the feed roller and the retarder roller. Hold the sheet by the tail end and, while moving the paper in and out between the retarder and feed roller, raise the retarder roller until you feel a slight pull on the paper. The retarder roller is raised and lowered via the thumb nut under the feed table (See Figure 3). Hold the paper and, rotate the hand wheel (Item 21), for one complete revolution of the feed roller. You should feel an even pull through the entire revolution of the feed roller. If at any point you do not feel an even pull, readjust the retarder roller.

For power-on setting, place one sheet of paper between the feed roller and the retarder roller. Hold the sheet by the tail end and turn on the machine. Adjust the retarder roller until you feel a consistent pull on the paper.

Turn power off and remove the paper.

To test for correct setting of the retarder roller, connect the machine to an electrical outlet. Place three sheets of

the paper to be folded onto the feed table. Turn on the folder. Single sheets should be forwarded into the machine. If they are not, readjust the retarder roller. Through normal use, the retarder roller will develop a flat wear area. When worn to the point that it will no longer contact the feed roller, loosen the nut on the retarder locking screw. Rotate in the proper direction (See Figure 3) to expose a new surface and lock into position.

**NOTE: The retarder roller should always be locked in a stationary position.**

### **3.0 Fold Settings & Operation**

The 1501 can be set up to make all standard folds including; letter, double parallel, Z, and single. The fold chart on the receiving tray (See Figure 11.) illustrates the standard fold table paper stop settings for making the various types of folds (inch and metric paper sizes). 1st refers to the letter setting on the 1st fold table scales (Item 17). 2nd refers to the letter setting of the 2nd fold table scales (Item 35). The following instructions assume a standard 8-1/2" x 11" sheet is being folded. Non-standard sizes should be measured and paper stops set according to measurements.

#### **3.1 Letter Fold Setup (See Figure 4.)**

1. Loosen the paper stop locking knobs on the 1st fold table (Item 16) and move the paper stop (Item 15) to the center of the letter A circle. Retighten the locking knobs.
2. Place the 2nd fold table (Item 34) into position with the open (folding) end toward the folding rollers. Loosen the paper stop locking knobs on the 2nd fold table and move the paper stop (Item 15) to the center of the letter S circle. Retighten the locking knobs.
3. Place a sheet on the feed table and set the paper guides so the sheet is centered over the feed roller and slides freely down between the guides without excessive side play. To aid paper feeding, slide the paper guide rollers on the feed roller shaft until they are 1/4" to 1/2" from the left and right edge of the paper to be folded.
4. Set the retarder roller as described in the section on feed adjustment.
5. Jog the paper to be folded on a Martin Yale Model 400 or 4200 Jogger for at least one minute, or hand jog. (Jogging dissipates static electricity and fluffs the paper.)
6. Take a stack of jogged paper and fan the paper out as indicated in Figure 9.
7. Place the fanned paper onto the feed table (See Figure 8.) with the top sheet positioned where the feed roller and retarder meet.
8. Manually feed one sheet through the machine and position the receiving tray (Item 19) so the folded sheet exits properly onto the tray.
9. Turn on the folder and fold several sheets. Stop the folder and inspect the folded sheets for accuracy.
10. Make 1st fold correction with the 1st fold table paper stop. Make 2nd fold correction with the 2nd fold table paper stop. (See Figure 4 for first and second fold descriptions.)
11. After corrections are made, turn on the folder and complete the folding job.

#### **3.2 Z Fold Setup (See Figure 5.)**

1. Loosen the paper stop locking knobs on the 1st fold table (Item 16) and move the paper stop (Item 15) to the center of the letter B circle. Retighten the locking knobs.
2. Place the 2nd fold table (Item 34) into position with the open (folding) end toward the folding rollers. Loosen the paper stop locking knobs on the 2nd fold table and move the paper stop (Item 15) to the center of the letter S circle. Retighten the locking knobs.
3. Set the paper guides so a sheet is centered over the feed roller and slides freely down between the guides

without excessive side play. To aid paper feeding, slide the paper guide rollers on the feed roller shaft until they are 1/4" to 1/2" from the left and right edge of the paper to be folded.

4. Set the retarder roller as described in the section on feed adjustment.
5. Jog the paper to be folded on a Martin Yale Model 400 or 4200 Jogger for at least one minute, or hand jog. (Jogging dissipates static electricity and fluffs the paper.)
6. Take a stack of jogged paper and fan the paper out as indicated in Figure 9.
7. Place the fanned paper onto the feed table (See Figure 8.) with the top sheet positioned where the feed roller and retarder meet.
8. Manually feed one sheet through the machine and position the receiving tray so the folded sheet exits properly onto the tray.
9. Turn on the folder and fold several sheets. Stop the folder and inspect the folded sheets for accuracy.
10. Make 1st fold correction with the 1st fold table paper stop. Make 2nd fold correction with the 2nd fold table paper stop. (See Figure 5 for first and second fold descriptions.)
11. After corrections are made, turn on the folder and complete the folding job.

### **3.3 Setup for Double Parallel Fold (See Figure 7.)**

1. Loosen the paper stop locking knobs on the 1st fold table (Item 16) and move the paper stop (Item 15) to the center of the letter C circle. Retighten the locking knobs.
2. Place the 2nd fold table (Item 34) into position with the open (folding) end toward the folding rollers. Loosen the paper stop locking knobs on the 2nd fold table and move the paper stop (Item 15) to the center of the letter U circle. Retighten the locking knobs.
3. Set the paper guides so a sheet is centered over the feed roller and slides freely down between the guides without excessive side play. To aid paper feeding, slide the paper guide rollers on the feed roller shaft until they are 1/4" to 1/2" from the left and right edge of the paper to be folded.
4. Set the retarder roller as described in the section on feed adjustment.
5. Jog the paper to be folded on a Martin Yale Model 400 Jogger for at least one minute, or hand jog. (Jogging dissipates static electricity and fluffs the paper.)
6. Take a stack of jogged paper and fan the paper out as indicated in Figure 9.
7. Place the fanned paper onto the feed table (See Figure 8.) with the top sheet positioned where the feed roller and retarder meet.
8. Manually feed one sheet through the machine and position the receiving tray so the sheet exits properly onto the tray.
9. Turn on the folder and fold several sheets. Stop the folder and inspect the folded sheets for accuracy.
10. Make 1st fold correction with the 1st fold table paper stop. Make 2nd fold correction with the 2nd fold table paper stop. (See Figure 7 for first and second fold descriptions.)
11. After corrections are made, turn on the folder and complete the folding job.

### **3.4 Single Fold Setup (See Figure 6.)**

1. Loosen the paper stop locking knobs on the 1st fold table (Item 16) and move the paper stop to the center of the letter C circle. Retighten the locking knobs.
2. Place the 2nd fold table (Item 34) into position with the closed (deflecting) end toward the folding rollers.
3. Set the paper guides so a sheet is centered over the feed roller and slides freely down between the guides without excessive side play. To aid paper feeding, slide the paper guide rollers on the feed roller shaft until they are 1/4" to 1/2" from the left and right edge of the paper to be folded.

4. Set the retarder roller as described in the section on feed adjustment.
5. Jog the paper to be folded on a Martin Yale Model 400 Jogger for at least one minute, or hand jog. (Jogging dissipates static electricity and fluffs the paper.)
6. Take a stack of jogged paper and fan the paper out as indicated in Figure 9.
7. Place the fanned paper onto the feed table (See Figure 8.) with the top sheet positioned where the feed roller and retarder meet.
8. Manually feed one sheet through the machine and position the receiving tray so the sheet exits properly onto the tray.
9. Turn on the folder and fold several sheets. Stop the folder and inspect the folded sheets for accuracy.
10. Make first fold correction with the 1st fold table paper stop. (See Figure 6.)
11. After corrections are made, turn on the folder and complete the folding job.

### **3.5 Setup for Stapled Sets**

We do not recommend folding stapled sets as it shortens the life of the folding rollers. If you choose to fold stapled sets with the 1501, we suggest the following procedure.

1. Adjust the retarder to the thickness of the stapled set. **NOTE: Do not attempt to fold more than three stapled sheets of 20# stock at one time.**
2. Use two staples, one on each side of the paper, parallel to the top edge.
3. Proceed with the folding job.
4. If this procedure is not successful, raise the retarder to maximum opening and hand-feed individual sets.

### **3.6 French Fold Setup**

Please follow these instructions for setup of the French fold. The paper stop settings for this fold are not listed on the simplified fold chart.

1. The French fold requires running the material through the folder in two steps. For step one, set the folder up as described in the single fold setup (See Section 3.4.) for the size paper to be folded.
2. Run the entire folding job through the 1501.
3. For step two, set the folder up as described in the single fold setup (See Section 3.4.) to the size you intend to refold. When setting the paper guides, position the guides so the folded edge of the sheet is closer to the feed roller. This helps prevent skewing of the folded paper.
4. Set the retarder (slip fit) for double thickness of the material to be folded.
5. Run the entire folding job through the 1501.

### **3.7 Baronial Fold Setup**

Please follow these instructions for setup of the Baronial fold. The paper stop settings for this fold are not listed on the simplified fold chart.

1. The Baronial fold requires running the material through the folder in two steps. For step one, set the folder up as described in the single fold setup (See Section 3.4.) for the size paper to be folded.
2. Run the the entire folding job through the 1501.
3. For step two, set the folder up as described in the letter fold setup (See Section 3.1.) to the size you intend to refold. When setting the paper guides, position the guides so the folded edge of the sheet is closer to the

feed roller. This helps prevent skewing of the folded paper.

4. Set the retarder (slip fit) for double thickness of the material to be folded.
5. Run the entire folding job through the 1501.

## 4.0 Maintenance

### 4.1 Feed Roller

After a period of normal operation, the feed roller will become coated by ink, toner, lint, and other contaminants. Clean the feed roller by wiping with a damp cloth containing a mild soap and water solution.

**NOTE: Do not use rubber roller cleaner or other solvents on the feed roller.** To maximize the gripping power of the feed roller and to remove any remaining contaminants, go over the feed roller surface with medium grit emery cloth. Replace the feed roller when grooves on the feeding surface are no longer visible (feed roller appears smooth).

### 4.2 Folding Rollers

During normal operation, the folding rollers will become coated with ink, toner, lint, and various other contaminants. Contaminated folding rollers can cause a variety of feeding problems. We recommend cleaning the folding rollers after every folding job, according to the following procedure. Regular cleaning will ensure optimum performance and add years of life to the folding rollers.

1. Make sure power has been disconnected and locked out.
2. Remove the feed table, 2nd fold table, and receiving tray.
3. Liberally spray Martin Yale Rubber Roller Cleaner and Rejuvenator onto a clean, dry cloth. Roller Cleaner and Rejuvenator has been specifically formulated for use in cleaning the folding rollers. Use of any other cleaner may deteriorate the rollers and void machine warranty.
4. Briskly clean each roller until no more contaminants appear on the cloth surface. Rotate the rollers via the handwheel and continue to clean until all roller surfaces are smooth and resilient, not hard or glazed.
5. If necessary, remove any glaze with a non-abrasive cleaning pad, such as a 3M Scotchbrite pad.
6. After cleaning, turn on the machine and let it run a few minutes to evaporate any cleaner left on the folding rollers.

### 4.3 Bearings

After each 8 hours of machine operation, thoroughly clean the folding rollers and remove any contaminants from the ends of the rollers and bearings. (See Figure 10.) Lubricate all bearings and shafts with one drop of light machine oil on each. **CAUTION: Do not allow any oil to come in contact with the folding rollers. If oil is spilled on the folding rollers, remove immediately with Martin Yale Rubber Roller Cleaner and Rejuvenator.**

## 5.0 Troubleshooting

### 5.1 Paper Will Not Feed

| Possible Cause                          | Solution  |
|---|---|
| Feed table not properly seated.         | Make sure the feed table is mounted correctly on the locating pins.                                   |
| Paper guides too tight (paper buckles). | Adjust the paper guides so a sheet slides freely down between the guides without excessive side play. |

Improper fanning of paper.

Grasp a stack of paper and place it on its long side on a flat, level surface. Even the paper and grip it tightly with your left hand. Loosely grip the paper with your right hand and pull the paper to you until it forms a semi-circle. Now tightly grip and hold the right side as you relax your left hand grip. (See Figure 9 for diagram of properly fanned paper.)

Worn out feed roller.

Replace the roller.

Feed roller contaminated.

See instructions in feed roller section.

Retarder set too tight.

Readjust the retarder.

Flat area on retarder.

Reset according to instructions in feed adjustment section.

Static electricity buildup.

Jog paper. Spray Martin Yale Static Eliminator liberally over paper edges, feed table, fold tables, and receiving tray.

Loose motor belt.

Adjust or replace motor belt.

## **5.2 Improper Stacking**

### **Possible Cause**

### **Solution**

Receiving tray improperly set.

Reset the receiving tray to slightly longer than the folded paper.

Static buildup.

Jog paper. Ensure that anti-static tinsel strip is installed. Spray Martin Yale Static Eliminator liberally over paper edges, feed table, fold tables, and receiving tray.

## **5.3 Crooked Folds**

### **Possible Cause**

### **Solution**

Excessive side play between paper guides and paper edges.

Readjust the paper guides to eliminate excessive side play.

Fold table paper stops improperly set or not locked in position.

Readjust the paper stops and lock in position.

Paper not square.

Recut paper until square. (Or adjust fold table paper stops.)

Contaminated folding rollers.

Clean according to instructions in maintenance section.

## **5.4 Ink Smudges on Paper**

### **Possible Cause**

### **Solution**

Ink not dry.

Allow additional ink drying time before folding. Some

inks **do not dry**, they only set (dry to the touch). Because of the physical nature of friction feeding, you may notice a mark on the leading edge of the paper.

Excessive toner on photocopied stock.

Check copy machine.

## **5.5 Jams**

### **Possible Cause**

More than a single sheet feeding into the folder.

### **Solution**

Readjust the retarder according to instructions in the feed adjustment section.

Folded sheets backing onto the folder.

Reset the receiving tray to slightly longer than the folded paper.

## **5.6 Wrinkled Paper**

### **Possible Cause**

Feed table paper guides misaligned.

### **Solution**

Align paper guides perpendicular to the folding rollers until paper feeds straight into the folder.

Feed table paper guides too tight.

Set guides so a sheet slides freely down between the guides without excessive side play.

Folding roller springs worn.

Replace with new springs.

Contaminated folding rollers.

Clean according to instructions in maintenance section.

Worn folding rollers.

Folding rollers should be replaced when gaps appear between the rollers.

## **5.7 Paper Exits on Top of Fold Table**

### **Possible Cause**

Contaminated folding rollers.

### **Solution**

Clean according to instructions in maintenance section.

Static buildup. Jog paper.

Spray Martin Yale Static Eliminator liberally over paper edges, feed table, fold tables, and receiving tray.

## **5.8 Folds More Than a Single Sheet**

### **Possible Cause**

Improper gap between retarder and feed roller.

### **Solution**

Readjust the retarder according to instructions in the feed adjustments section.

## **Introduction**

Nous vous remercions d'avoir choisi le Martin Yale Model 1501 Auto PliEUR. Le 1501 peut exécuter les plages lettre, Z, unique, double parallèle, français, Baronial, et les pliages sur mesure dans sa capacité de taille de la feuille.



# REFERENCE ILLUSTRATIONS

Fig. 1 - Feed Table Installation

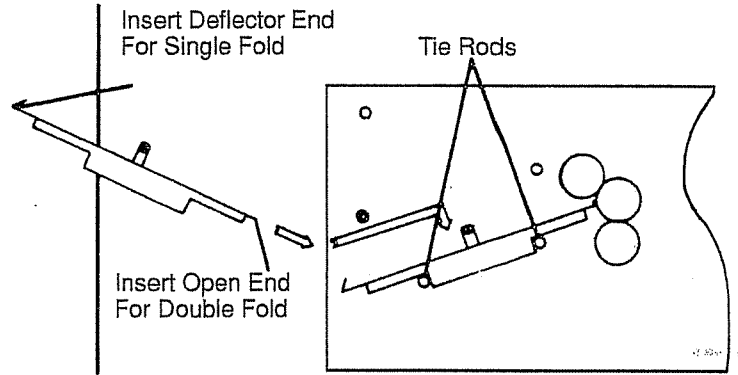
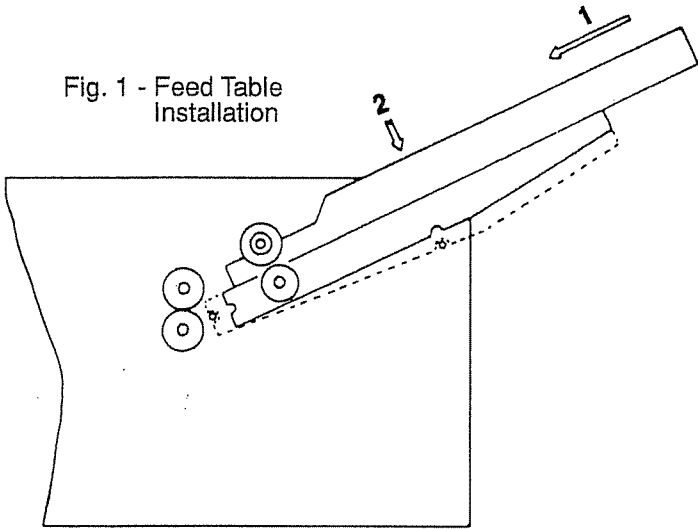

Fig. 2 - Fold Table Installation

Fig. 3 - Feed Adjustment

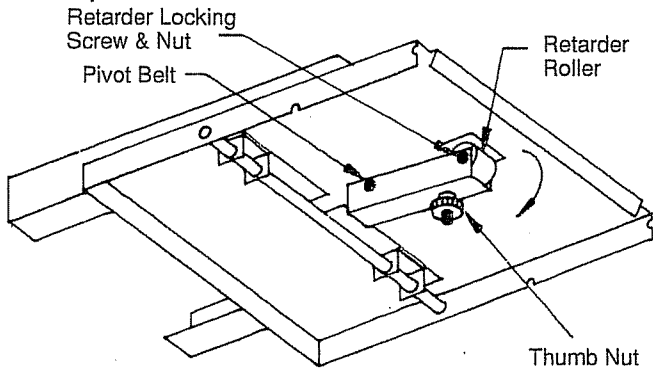
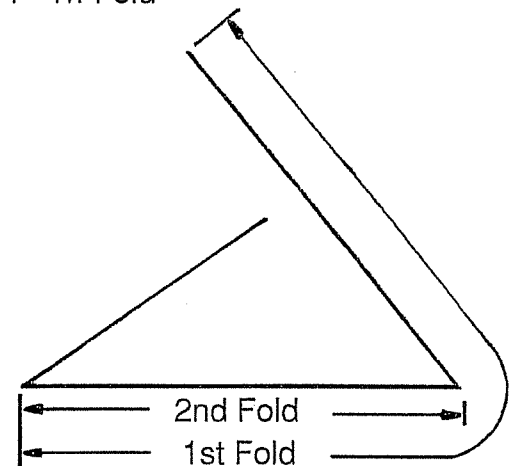

Fig. 4 - Tri-Fold



# REFERENCE ILLUSTRATIONS (con't)

Fig. 5 - Z-Fold

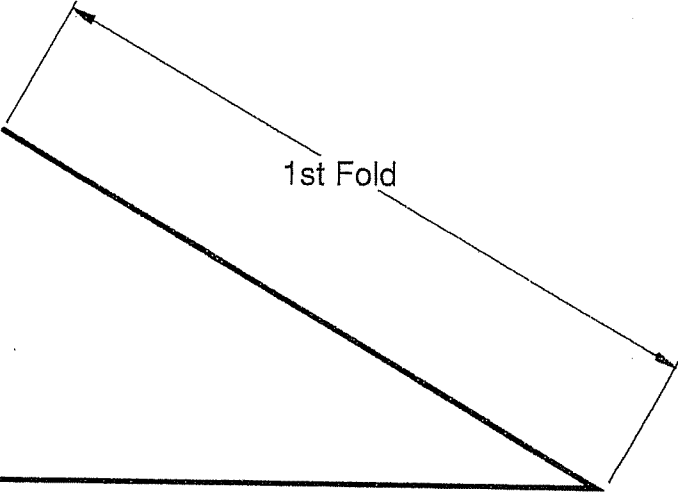
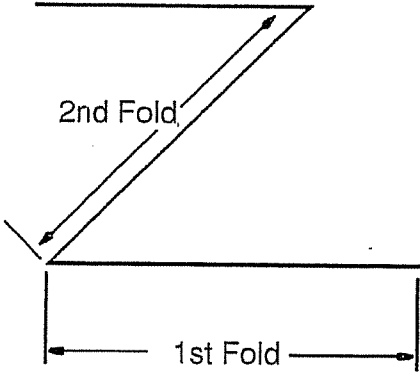

Fig. 6 - Single Fold

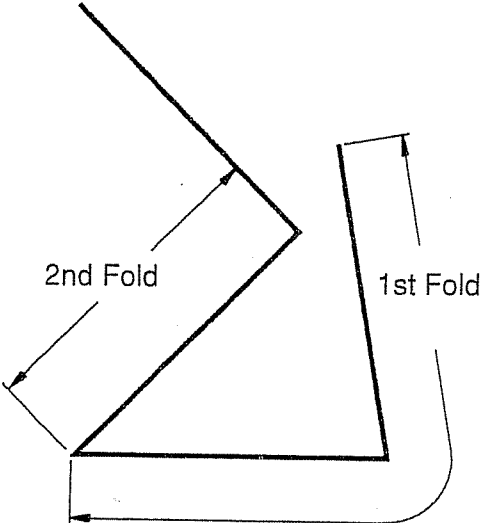

Fig. 7 - Double Parallel

# REFERENCE ILLUSTRATIONS (con't)

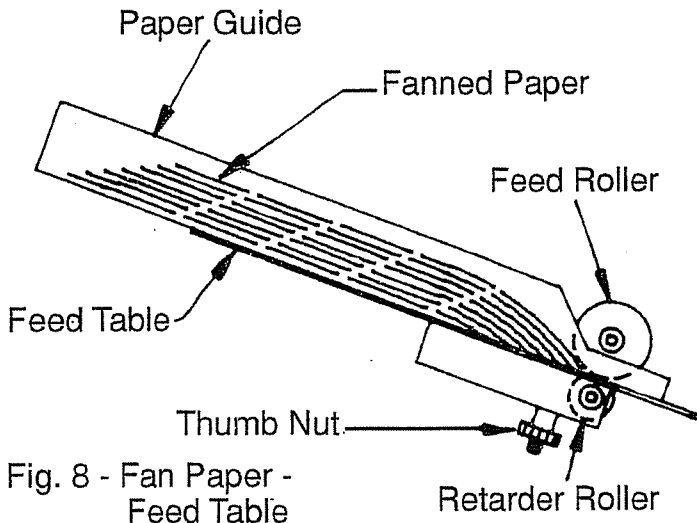

Fig. 8 - Fan Paper - Feed Table

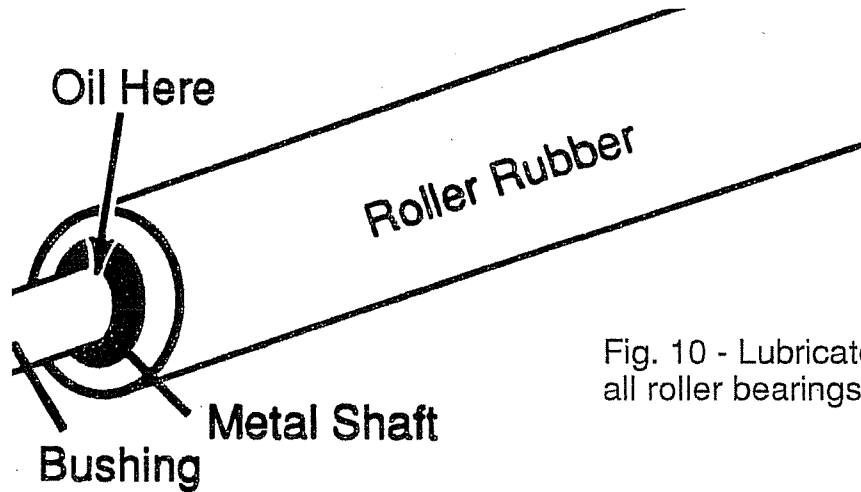

Fig. 10 - Lubricate all roller bearings

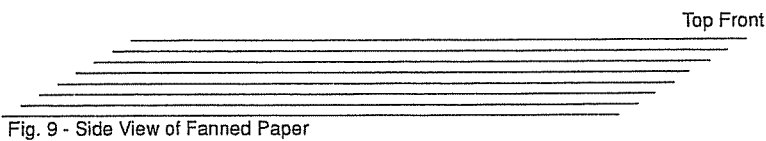
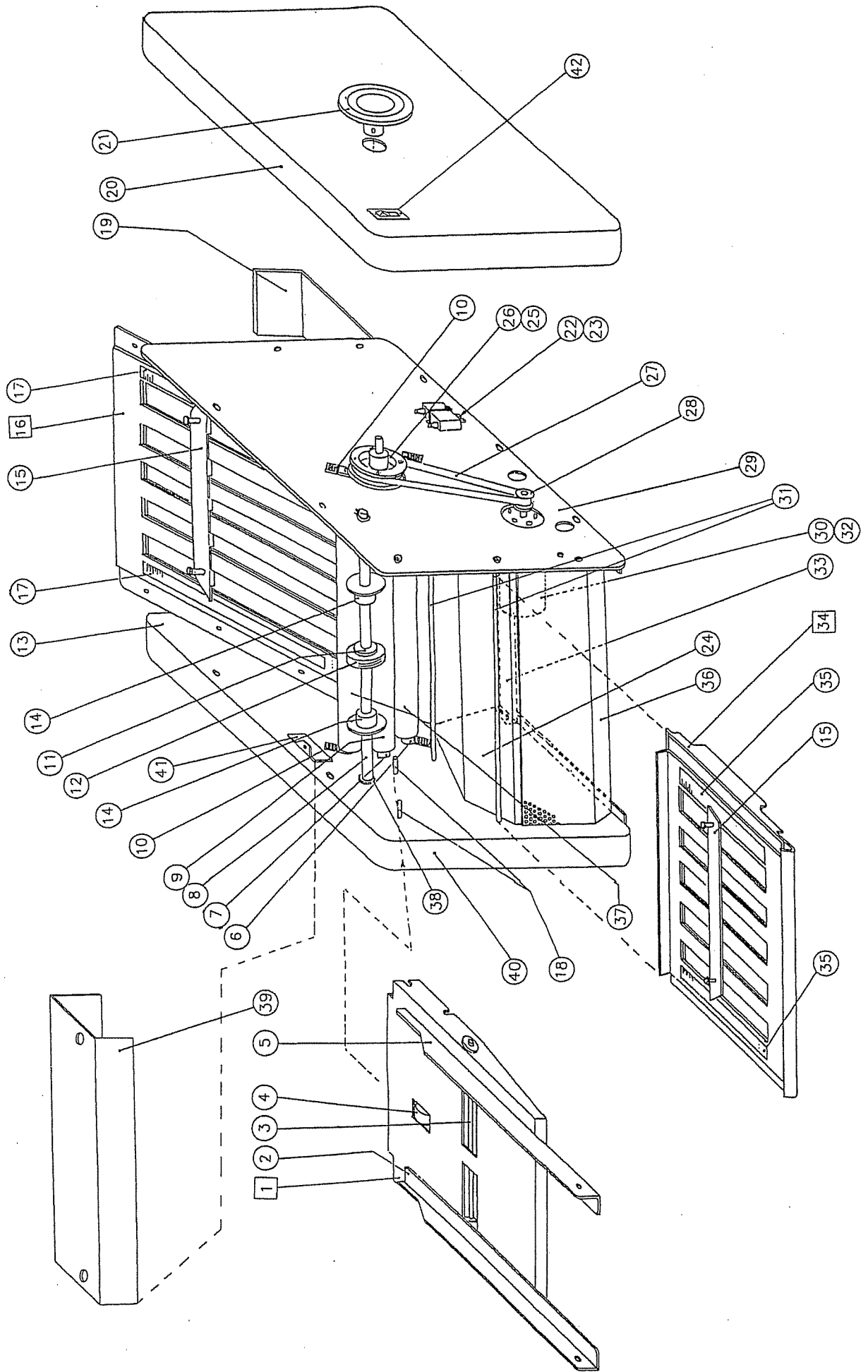

Fig. 9 - Side View of Fanned Paper

|              |                 | SIMPLIFIED FOLDING CHART  |            |          |    |     |
|--------------|-----------------|---------------------------|------------|----------|----|-----|
|              |                 | PAPER SIZE                |            |          |    |     |
| TYPE OF FOLD |                 | 8 1/2 X 11                | 8 1/2 X 14 | *11 X 17 | A4 | *A3 |
| /            | 1 <sup>st</sup> | A                         | H          | P        | J  | Q   |
|              | 2 <sup>nd</sup> | S                         | Y          | E        | K  | X   |
| \            | 1 <sup>st</sup> | B                         | I          | F        | N  | C   |
|              | 2 <sup>nd</sup> | S                         | Y          | E        | K  | X   |
| /            | 1 <sup>st</sup> | C                         | D          | G        | R  | T   |
|              | 2 <sup>nd</sup> | U                         | Z          | W        | V  | L   |
| \            | 1 <sup>st</sup> | C                         | D          | G        | R  | T   |
|              | 2 <sup>nd</sup> | REVERSE SECOND FOLD TABLE |            |          |    |     |

1st: UPPER OR FIRST FOLD TABLE SETTING \*1217A MODEL ONLY  
2nd: LOWER OR SECOND FOLD TABLE SETTING

Fig. 11 - Folding Chart



□ Number in square indicates complete assembly

| Item |                                  |           |      | Item             |                                |            |      |
|------|----------------------------------|-----------|------|------------------|--------------------------------|------------|------|
| No.  | Description                      | Part No.  | Qty. | No.              | Description                    | Part No.   | Qty. |
| 1    | Feed Table                       | W-A003508 | 1    | 27               | Timing Belt, #150XL037         | M-S025026  | 1    |
| 2    | Left Paper Guide                 | W-A01501L | 1    | 28               | Motor Pulley, 15T              | M-S022073  | 1    |
| 3    | Paper Guide Support Shaft        | W-O001541 | 1    | 29               | Right Side Main Frame          | W-O001589  | 1    |
| 4    | Retarder Roller/Arbor            | WRA001516 | 1    | 30               | Motor, 115V, PSC Type          | M-S021042  | 1    |
| 5    | Right Paper Guide                | W-A01501R | 1    | 31               | Tie Rods (2nd Fold Table)      | M-O001542  | 2    |
| 6    | Nylon Bearing                    | M-O007509 | 6    | 32               | Motor, 220V, PSC Type          | M-S021043  | 1    |
| 7    | Oillite Bronze Bearing           | M-S013010 | 2    | 33               | Paper Chute                    | W-O001585  | 1    |
| 8    | Feed Roller Shaft                | W-O001540 | 1    | 34               | 2nd Fold Table Assembly        | W-A001520  | 1    |
| 9    | Main Drive Roller (Long Journal) | WRA001530 | 1    | 35               | 2nd Fold Table Scale           | M-O001568  | 2    |
| 10   | Spring, Blue                     | M-S031035 | 4    | 36               | Screen Guard                   | W-O001587  | 1    |
| 11   | Feed Roller Arbor                | M-O003125 | 1    | 37               | Intermediate Rollers           | WRA001532  | 3    |
| 12   | Feed Roller Rubber               | M-O003548 | 1    | 38               | Nyliner Bearing                | M-S014027  | 2    |
| 13   | Left Side Main Frame             | W-O001598 | 1    | 39               | Roller Guard (220V Only)       | W-O001588  | 1    |
| 14   | Paper Guide Rollers              | M-O003030 | 2    | 40               | Cover, Non-Operator's Side     | W-I001504  | 1    |
| 15   | Paper Stops                      | W-O001534 | 2    | 41               | Left Side Bracket (220V Only)  | W-O0095280 | 1    |
| 16   | 1st Fold Table Assembly          | W-A001519 | 1    | 42               | On/Off Switch                  | M-S033045  | 1    |
| 17   | 1st Fold Table Scale             | M-O001567 | 2    | <b>Not Shown</b> |                                |            |      |
| 18   | Fold Table Index Pins            | M-O003104 | 3    |                  | Taper Index Pin                | M-O095242  | 1    |
| 19   | Receiving Tray                   | W-O001596 | 1    |                  | Anti-Static Tinsel Assembly    | W-A001509  | 1    |
| 20   | Cover, Operators Side            | W-O001504 | 1    |                  | Gear, 24T, Plastic             | M-O003033  | 3    |
| 21   | Hand Wheel                       | M-S032009 | 1    |                  | Right Side Bracket (220V Only) | W-O095265  | 1    |
| 22   | Capacitor for 115V Motor         | M-S045101 | 1    |                  | Pulley, Plastic, 2 3/8 Dia.    | M-O001591  | 1    |
| 23   | Capacitor for 220V Motor         | M-S045102 | 1    |                  | Pulley, Steel, 7/8 Dia.        | M-O007507  | 1    |
| 24   | Motor Guard                      | W-O001586 | 1    |                  | Rubber Belt, Round             | M-S023001  | 1    |
| 25   | Pulley Flange                    | M-S022022 | 1    |                  | Fan, 10-Blade                  | M-S037361  | 1    |
| 26   | Pulley, 44T                      | M-S022019 | 1    |                  | Paper Stop Bracket             | W-O001507  | 1    |

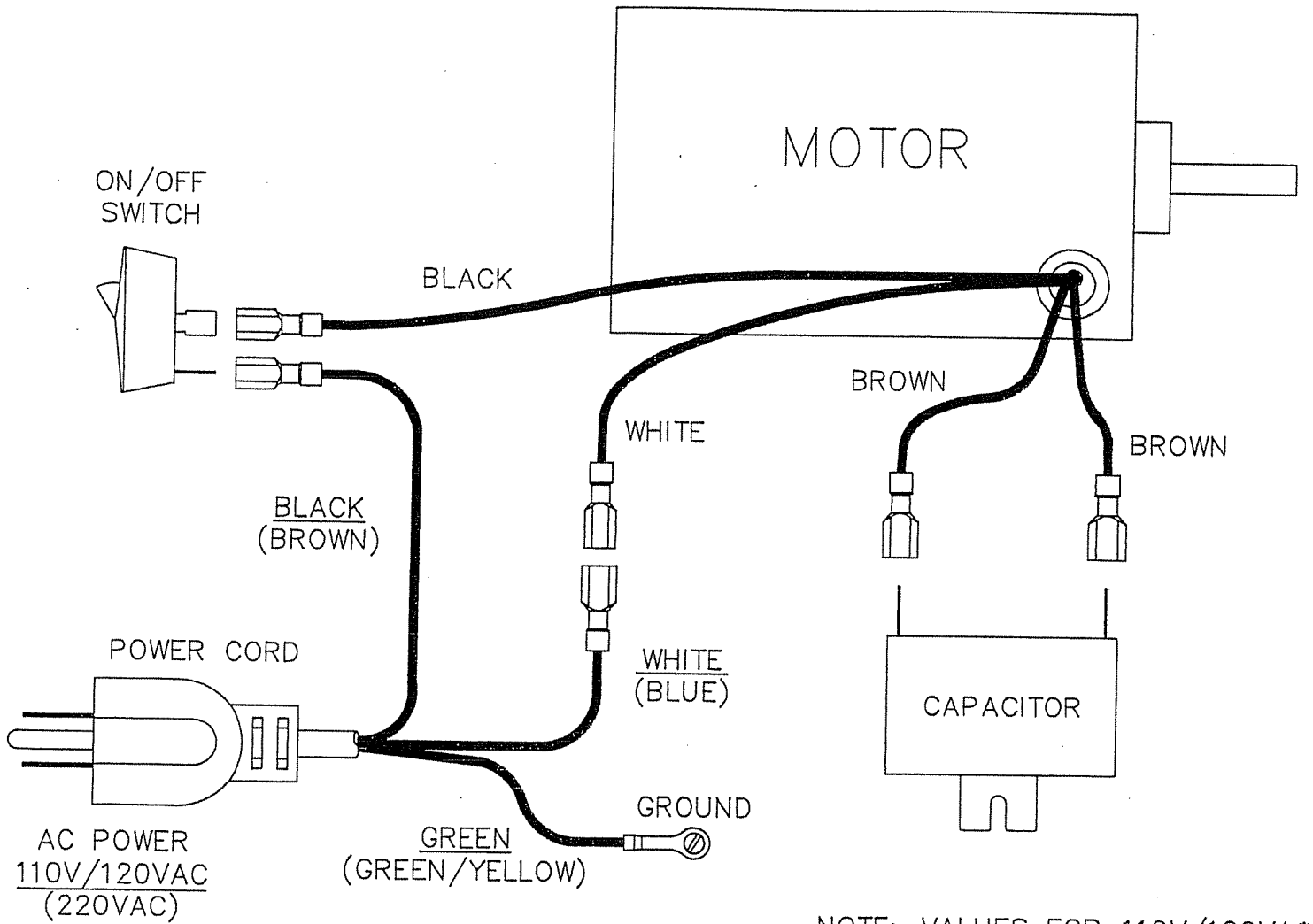

NOTE: VALUES FOR 110V/120VAC  
(VALUES FOR 220VAC)

MODEL 1501 WIRING DIAGRAM  
 FOR 110V/120VAC (220VAC)



251 Wedcor Avenue • Wabash, IN 46992  
Phone (219) 563-0641 • Fax (219) 563-4575  
Technical Support (219) 563-0641